

Hollow shaft micro servo actuators realized with the Micro Harmonic Drive®

R. Degen, R. Slatter
Micromotion GmbH, Mainz, Germany

Abstract:

The trend to miniaturization cannot be overseen. The use of very small electronic components in a variety of consumer goods makes necessary the use of small-scaled servo actuators for positioning applications in production equipment. The previous generation of micro gears and micro actuators was not suited to this type of application, because of unacceptable accuracy.

The Micro Harmonic Drive® gear was introduced into the market in 2001 as the world's smallest backlash-free micro gear. In the meantime this gear has been implemented in a new range of miniaturized servo actuators, which provide zero backlash, excellent repeatability and long operating life.

The latest development is the result of close cooperation between the gear manufacturer Micromotion GmbH and the leading motor manufacturer Maxon Motor AG. This joint development has resulted in the world's smallest backlash-free servo actuator for precise positioning applications.

In addition to the above-mentioned advantages this unique product also features a central hollow shaft. This allows the design engineer to pass an optical fiber, a laser beam or media such as fluids, compressed air or vacuum along the central axis of the servo actuator. This greatly simplifies the design of numerous machines and devices in the semi-conductor, medical and optical fields. In this paper we will describe the development history, key features and applications of this innovative new drive solution.

Introduction

Micro gear systems represent a key element in micro drive systems. Only by using suitable micro gear systems it is possible to apply existing micro motors operating with speeds of up to 100.000 rpm at output torques in the range of some μNm [1] in a wide field of different applications. To access new innovative fields of application in the range of micro drive systems Micromotion GmbH has developed a new generation of high precision and zero backlash micro gear system: the Micro Harmonic Drive® (see *Fig. 1*).



Fig. 1: High precision micro gear system based on the Harmonic Drive® principle

1 The Micro Harmonic Drive®

1.1 Principle of operation

Until now there have been no micro-gears suitable for precise positioning applications. They must not only be extremely small, but also exhibit the following features:

- A high repeatability
- Zero backlash
- A high reduction ratio
- A low parts count.

The solution is the principle of a Harmonic Drive® gear system. This kind of gear system stands out compared with other gear principles e.g. spur gears (see Fig. 2a) and planetary gear systems (see Fig. 2b), because of its high precision and zero backlash transmission properties.

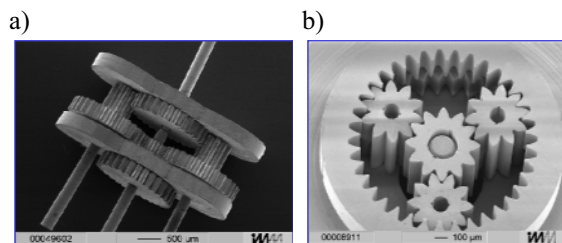

Fig. 2: a) Micro spur gear with two trains
b) Micro planetary gear system

Its exceptional properties have been proven for many years in the fields of industrial robots, machine tools, measuring machines, aerospace and medical equipment [2]. The Micro Harmonic Drive offers the following advantages, which are particularly important with reference to micro gear systems:

- Zero backlash yet miniaturized dimensions
- Excellent repeatability
- High torque capacity
- Only six components and therefore a high reliability
- High efficiency
- Extremely flat design
- Low weight
- Compact dimensions
- The high reduction ratio necessary for micro motors can be reached in a single gear stage.

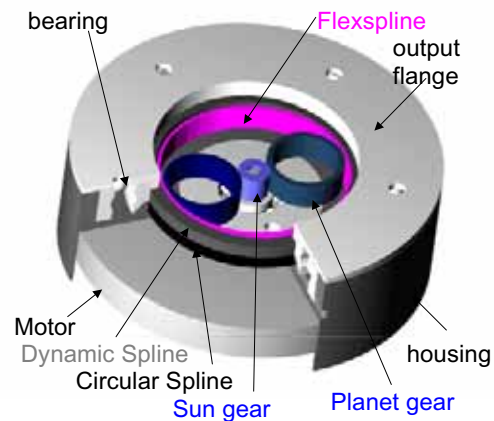

Fig. 3: The solution is the Micro Harmonic Drive®

The basic elements of the Micro Harmonic Drive® gear system are the Wave Generator consisting of two planetary wheels and a sun gear wheel and the three gear wheels

- Flexspline,
- Circular Spline and
- Dynamic Spline.

The Wave Generator deflects the elastically deformable Flexspline elliptically across the major axis. Due to that the teeth of the Flexspline engage simultaneously with the two ring gears - Circular Spline and Dynamic Spline - in two zones at either end of the major elliptical axis (see Fig. 4). Across the minor axis of the elliptically deflected Flexspline there is no tooth engagement.

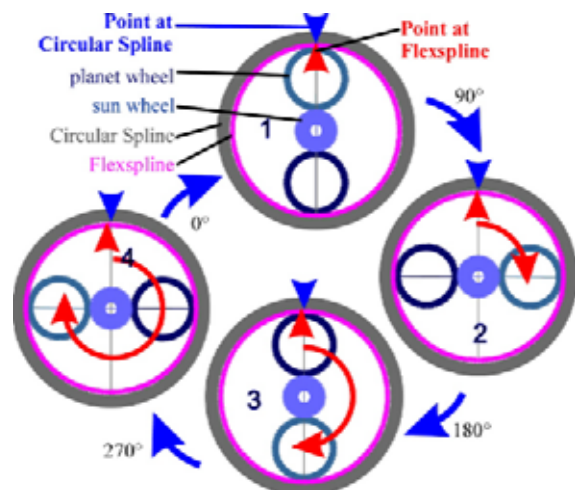

Fig. 4: Operating principle of the Micro Harmonic Drive® gear

When the sun wheel of the Wave Generator rotates, the zones of tooth engagement of the Flexspline travel with the angular position of the planet wheels of the Wave Generator. A small difference in the number of teeth between the Flexspline and the

Circular Spline (the latter has two teeth more) results in a relative movement between these gear wheels. After a complete rotation of the planet wheels of the Wave Generator the Flexspline moves relative to the Circular Spline by an angle equivalent to two teeth. The Dynamic Spline is used in the flat type gear system as the output element and has the same number of teeth as the Flexspline and therefore the same rotational speed and direction of rotation.

With respect to the planned miniaturization of the Micro Harmonic Drive[®] the planetary gear configuration for the Wave Generator possesses the following advantages:

- All gear components can be manufactured using the high precision LIGA-technique
- The assembly effort can be minimized, because the Wave Generator consists of only three components
- The total reduction ratio of the gear increases due to the planetary gear. This design can therefore flexibly adapt the very high rotational speed of micro motors in only one stage to the specific requirements of a given application
- This variant of the Wave Generator possesses only a low moment of inertia and therefore enables a highly dynamic positioning performance

By using a planetary gear for the Wave Generator it is possible to vary the total ratio of the Micro Harmonic Drive[®] over a large range. For the shown gear size, reduction ratios from 160 up to 1000 can be realized in a single stage.

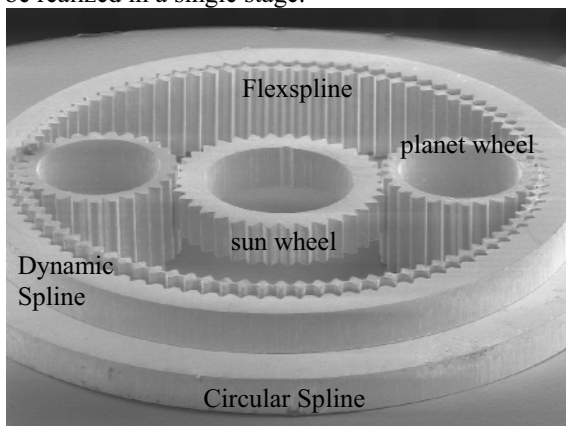

Fig. 5: Components of the Micro Harmonic Drive[®] Gear

Excluding the input and output bearing arrangements the outer dimensions of the Micro Harmonic Drive[®] are 1 mm axial length and 8 mm in diameter (see Fig. 5).

A gear module of 34 μm must be used to realize the necessary high reduction ratio and the small dimensions simultaneously. The single gear wheels of the Micro Harmonic Drive[®] are manufactured by electroplating and consist of a nickel-iron-alloy. Due to the high yield point of 1.500 N/mm^2 , the low elastic modulus of 165.000 N/mm^2 and its good fatigue endurance [3] this electroplated alloy possesses the necessary properties for perfect functioning of the flexible gear wheels of this micro gear system.

1.2 Flexible gear wheels

The Flexspline represents the most challenging component of the Micro Harmonic Drive[®] (see Fig. 6).

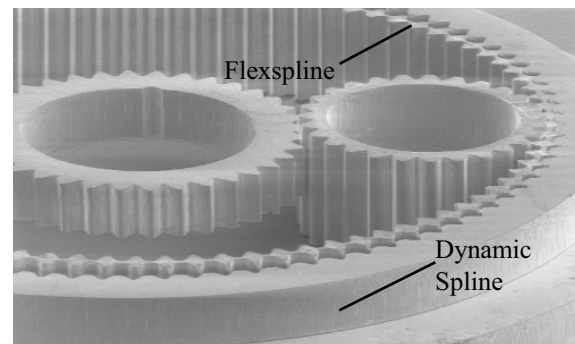

Fig. 6: Internal and external teeth of the Flexspline

Contrary to conventional gear systems based on the Harmonic Drive[®] operating principle, the Flexspline of the Micro Harmonic Drive[®] needs in addition to its very thin ring thickness an internal and external toothing simultaneously. This duplex toothing is necessary due to the planetary gear configuration of the Wave Generator. To achieve trouble-free operation the Flexspline must exhibit uniform deflection behavior. This is realized by using the same number of teeth for the external and internal toothing. The production of the duplex toothing and the thin ring thickness necessary for low bending stresses when the Flexspline is deflected is made possible by using the LIGA-technique [4]. Because of this technique it is possible to realize a ring thickness in the tooth root of only 40 μm for a tooth width of 1000 μm .

Another component contributing essentially to the zero backlash and precise operating behavior of the Micro Harmonic Drive[®] is the flexible planet wheel of the Wave Generator. Both planet wheels have the primary task of realizing the exact deflection of the Flexspline. Additionally the planet wheels have to compensate errors of fabrication and wear of the

gear system whilst still providing an exact deflection of the Flexspline. This error compensating property of the planet wheels is made possible by their design as a spring element. Therefore the flexible properties of a tube with a thin ring thickness acting in a radial direction can be used. The planet wheel is designed as a thin ring providing simultaneously enough flexibility to compensate errors yet rigid torsional stiffness. The Flexspline is pressed by the planet wheels simultaneously into engagement with the Circular Spline and the Dynamic Spline. Consequently errors in both zones of tooth engagement are compensated by their spring travel (see Fig. 7).

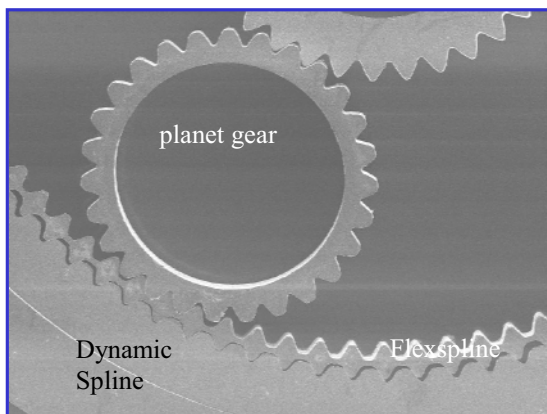

Fig. 7: Zero backlash by means of flexible planet wheels

As a result both external and internal teeth of the Flexspline are brought into contact with the leading and return faces of the teeth of the meshing gear wheels. The preload of the gear system provided by the flexible planet wheels is the basis for the zero backlash transmission behavior and high positioning precision of the Micro Harmonic Drive®.

2 New developments: A hollow shaft version and a range of micro-gearboxes

Due to its special design the Micro Harmonic Drive® offers not only the possibility to realize a very high transmission ratio without backlash. Another important property for systems which are optimized with respect to their outer dimensions is the possibility to realize a hollow shaft. This means that a hollow shaft can be passed straight through the gear system along the central rotational axis. This hollow shaft, which passes through the sun gear (see Fig. 8) is important for a wide range of different functions.

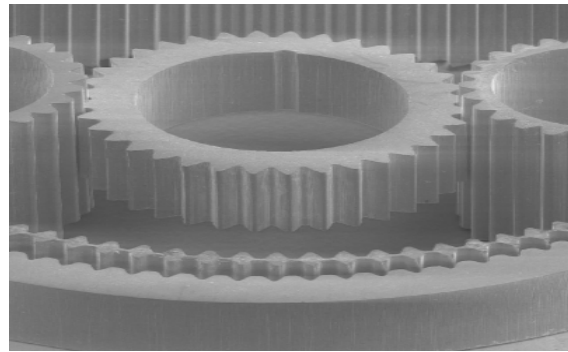

Fig. 8: The central bore in the sun gear enables a hollow shaft

Especially in the field of devices optimized with respect to outer dimensions the possibility of a hollow shaft offers significant opportunities to reduce the outer dimensions of the whole system. Different kinds of signals or media needed for the application can be transported through the hollow shaft. The hollow shaft can be used e.g. for sensors or for optical fibers. Additionally vacuum or air can be transmitted through the hollow shaft to the output side of the gear.

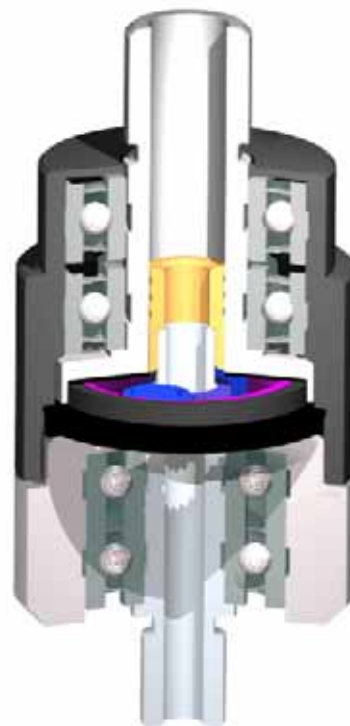

Fig. 9: The new micro-gearbox MHD 10-160-SP with hollow shaft

Fig. 9 shows a section of a gear unit of the MHD10-160-SP micro-gearbox. This gear unit features a pre-loaded duplex bearing for the input and output shaft. A hollow shaft with an inner diameter of 1 mm passes through the complete gearbox.

Another new development is represented by the MHD micro-gearbox range:

- MHD 8
- MHD 10

The MHD 10 model uses the existing gear size with an outer diameter of 8 mm. The MHD 10 model has a housing diameter of 10 mm and a centering shoulder of 9 mm serving simultaneously for axial location. The MHD 10 model is provided with the reduction ratios 160, 500 and 1000 and can be built up both with and without hollow shaft (see **Fig. 10**).

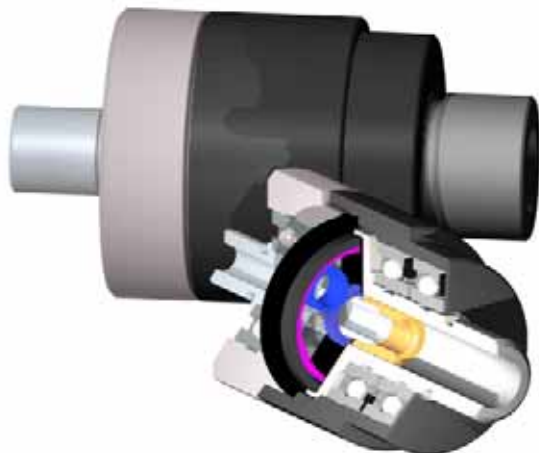

Fig. 10: The new micro-gearbox models: MHD 10 and MHD 8 shown as unit with hollow shaft

The MHD 8 model uses a newly developed and further miniaturized gear component set with an outer diameter of only 6 mm. The MHD 8 model features a housing diameter of 8 mm with a centering shoulder of 7 mm. The reduction ratios 160 and 500 are available for this model (see **Fig. 10**). Both models are available as a unit with an input and output shaft or directly coupled with several types of currently available micro motors.

3 Experimental analysis and data

The very low friction torque of this zero backlash micro gear system is based on the exact dimensioning of the gear wheels and the high precision reached by using the LIGA-technique for manufacture. In spite of the pre-load of the wave generator, which is necessary to realize a zero backlash gear system, the maximum measured friction torque is only 16 μNm (see **Fig. 11**).

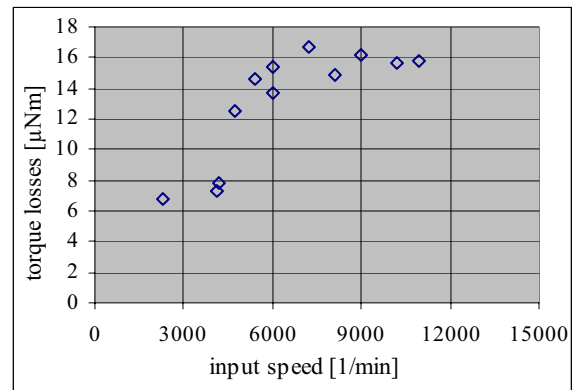

Fig. 11: Correlation between input speed and friction torque

The measured maximum value of the efficiency of the Micro Harmonic Drive[®] gear amounts to 40 % for a transmission ratio of 500 (see **Fig. 12**).

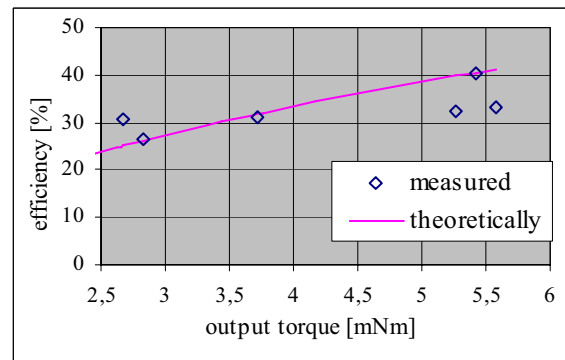

Fig. 12: Correlation between output torque and efficiency

The measuring results illustrated in **Fig. 12** show the steady increase of the efficiency with increasing output torque. Due to the monotonic increasing trend of the measured points and the progress of the theoretical curve a further increase of efficiency may be expected towards still higher torques

Additionally to its low friction torque and high efficiency the Micro Harmonic Drive[®] is distinguished especially by its excellent transmission qualities in comparison to other gear systems. The repeatability, lost motion and the hysteresis are suitable criteria to describe the quality of the transmission of a zero backlash gear system operating in positioning drive systems. The hysteresis describes the effects of a changing output load of the angular position of the output shaft of the gear and simultaneously its torsional stiffness. The value of the lost motion describes the angular error, which results by positioning movement from opposite directions.

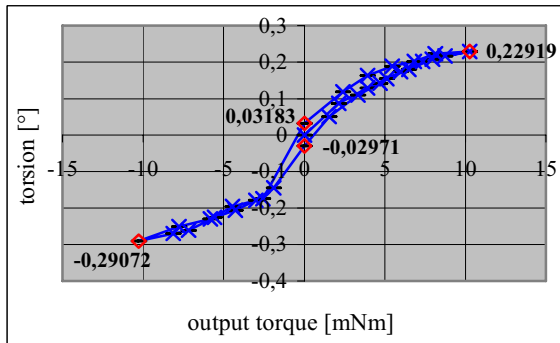

Fig. 13: Hysteresis of the Micro Harmonic Drive®

The high efficiency and precise transmission behavior of the zero backlash Micro Harmonic Drive® is shown clearly by the narrow hysteresis curve and the resultant low hysteresis losses of less than 0,1° (see Fig. 13).

The most important data and measured values of the realized Micro Harmonic Drive® are listed in Table 1.

Table 1: Technical gear data

dimensions:	diameter:	6 and 8 mm
	axial length:	1 mm
transmission ratio:		160
		500
		1000
gear module:		34 µm
material:		Nickel-iron
efficiency:		40 %
output torque:		50 mNm*
torque loss:		16 µNm
repeatability:		±10''
lost motion:		10''
hysteresis losses:		0,1°
Torsional stiffness:		2,6 Nm/rad

* for 8mm diameter gear

Due to its properties, especially its high repeatability and its lost motion lower than 10 arc seconds the Micro Harmonic Drive® is ideally suited for applications in high precision micro positioning drive systems. Micromotion GmbH, located in Mainz in Rhineland Palatinate, is focused on the development and manufacture of micro gears and micro actuators using the Micro Harmonic Drive® principle.

4 Micro drive systems

The Micro Harmonic Drive® can be combined with all currently available micro motors, e.g. stepping motors, AC or DC motors and pancake motors. The combination of the Micro Harmonic Drive® with a pancake motor, represents a powerful and geometrically matching micro drive system (see Fig. 14).



Fig. 14: Ultra flat micro drive system

The combination of Micro Harmonic Drive and pancake motor is also illustrated in Fig. 1. The pancake motor is distinguished by its small diameter of 12.8 mm and especially by its extremely flat height of 1.4 mm. By combining the ultra flat Micro Harmonic Drive® and the pancake shaped penny motor it is possible to realize a micro actuator with only 4.3 mm axial length and 13.4 mm diameter. This micro actuator provides an output torque of up to 10 mNm and rotational speeds up to 100 rpm with an operating weight of only 4.3 g. Additionally alternative output bearing arrangements for the Micro Harmonic Drive® can be realized to enable easy integration in a wide range of applications, e.g. an output shaft with preloaded bearings, output shaft with flange bearing and output flange with flange bearing.

5 The world's smallest backlash-free servo actuator

A further innovation is represented by the world's smallest backlash-free servo actuator. This latest development is the result of close cooperation between the gear manufacturer Micromotion GmbH and the leading motor manufacturer Maxon Motor AG. The main objective of this joint development is to provide a reliable and robust actuator for precise industrial positioning applications.

The servo actuator comprises a Maxon EC6 motor, an MR Encoder and the MHD 8-160-SP micro-gearbox with hollow shaft. It has the following properties (see **Fig. 15**):

- hollow shaft with \varnothing 0,65 mm
- transmission ratio of 160 :1

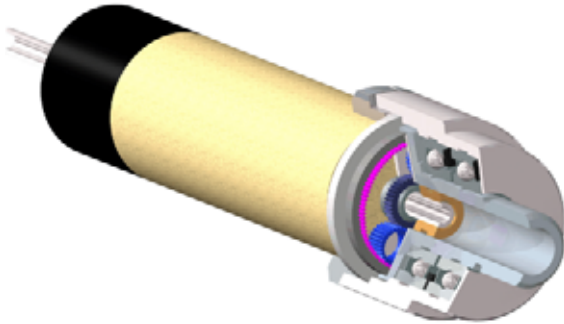

Fig. 15: World's smallest backlash-free servo actuator

The Maxon EC6 is an EC motor with only 6 mm outer diameter and with integrated Hall sensors for commutation. The motor has a maximum output speed of 100,000 rpm. The maximum continuous current is 500 mA and maximum continuous torque 0.260 mNm.

The digital MR encoder from Maxon supplies 100 pulses per revolution. It provides the TTL signals needed for servo-drives: the channels A and B. This gives the user the encoder signals that suit his individual requirements.

In **Fig. 16** you can see a size comparison of the complete servo actuator with a standard fibre optical connector for single mode fibres.



Fig. 16: Comparison between the servo actuator and an optical fiber connector

6 Applications for micro drive systems

Additionally to their small dimensions micro actuators incorporating the Micro Harmonic Drive[®] gear offer new advantages due to their low mass, low inertia and low power consumption combined with their excellent positioning accuracy and highly dynamic performance. The precision micro gears and micro actuators from Micromotion GmbH are a key enabling technology for a new generation of miniaturized devices in a wide range of application areas. The Micro Harmonic Drive[®] is ideally suited to precise positioning applications in the following fields:

- optics, e.g. to adjust lenses and mirrors,
- medical equipment, e.g. to dose drugs or to drive surgical instruments,
- optical communication, e.g. to switch or adjust fibers,
- semicon, e.g. to assemble, handle and adjust semi-conductor components,
- robotics, e.g. to drive axes of micro robots with high accuracy,
- laser technology, e.g. to adjust the beam by means of mirrors or lenses,
- biotechnology, e.g. to dose expensive materials and to adjust pipette probes,
- measuring machines, e.g. to adjust non-contacting sensors
- aircraft and spacecraft, e.g. to control nozzles or valves in nanosatellites.

7 Conclusion

New positioning applications in medical equipment, optics, micro robotics and semicon need new drives and gears with extremely small dimensions. Additionally to the small size these new applications need a high positioning accuracy and precise control. These requirements cannot be achieved using existing solutions of micro gear systems. The preferred functional principle of the existing solutions is represented by the planetary gear system. This gear operating principle needs several stages and therefore a lot of parts. The main disadvantage of the available products is their backlash of several degrees. Therefore a high positioning accuracy is not possible with existing solutions.

The Micro Harmonic Drive[®] sets new standards. This gear system combines the advantages of a compact build-up, a high power density and excellent properties of positioning. This all is realized using only six components. The consequences are that the Micro Harmonic Drive[®] is more precise, smaller, simpler and therefore more reliable than existing solutions.

Micromotion GmbH located in Mainz develops and manufactures the world's smallest zero backlash micro gear system, the Micro Harmonic Drive[®].

8 References

- [1] C. Thürigen, W. Ehrfeld, B. Hagemann, H. Lehr, F. Michel: Development, fabrication and testing of a multi-stage micro gear system. Proc. Of Tribology issues and opportunities in MEMS, pp. 397-402, Columbus (OH), November 1997, Kluwer Academic Publishers, 1998
- [2] R. Slatter: Weiterentwicklung eines Präzisionsgetriebes für die Robotik, Antriebstechnik, 2000
- [3] S. Abel: Charakterisierung von Materialien zur Fertigung elektromagnetischer Mikroaktoren in LIGA Technik, Diss. Universität Kaiserslautern, 1996
- [4] W. Ehrfeld, H. Lehr: Deep X-ray Lithography for the Production of three-dimensional Microstructures from Metals, Polymers and Ceramics, Radiat. Phys. and Chemistry 45 (1995) Nr. 3, 349-365
- [5] S. Kleen, W. Ehrfeld, F. Michel, M. Nienhaus, H.-D. Stölting: Ultraflache Motoren im Pfennigformat, F&M, Jahrg. 108, Heft 4, Carl Hanser Verlag, München, 2000

Harmonic Drive[®] is a registered trademark of Harmonic Drive AG, Limburg, Germany, and is used with permission.